

## Perspectives on Greek and Roman catapults

### Mark Hassall

***Both the Greeks and the Romans showed great ingenuity in developing catapults as artillery weapons. Evidence of how these complicated machines worked comes from surviving descriptions, experimental reconstructions and archaeological remains. Ancient technical drawings are a valuable but relatively neglected source of information about catapult design, and one that poses challenging problems of interpretation.***

**G**reek and Roman catapults – or torsion artillery as they are more correctly known – have attracted the attention of several different types of people, not least the directors of Hollywood “sword and sandal” epics such as *Spartacus*, and the experimental archaeologists in Roman military re-enactment societies such as the Ermine Street Guard. Catapults were complex machines (Fig. 1), whose design resulted from planned campaigns of research and development initiated by such men as Dionysius, the tyrant of Syracuse, in the early fourth century BC. They are also of interest to students of classical science and engineering, especially because the level of technology involved was considerable.<sup>1</sup> For example, the discovery at the site of Auerberg (southern Germany) of clay moulds for the production of bronze “spring washers” by the lost-wax process demonstrates the sheer technical competence of the men who produced these sophisticated bronze castings.<sup>2</sup>

More generally, the study of Greek and Roman catapults illustrates the maxim that, as in other branches of Western applied science, “the Greeks invented it first” and the Roman engineers were content simply to follow where others had led. Or were they? In the early second century AD there was something of a revolution in catapult design. The method of operation of the new machines is controversial, but according to one view (and it is a view to which I subscribe) they represent a radical rethink, so perhaps the Roman engineers weren’t so dumb after all. A discussion of this question is beyond the scope of this short article, but the interest it generates shows that the study of ancient artillery remains a lively and controversial subject – and some of it is going on at the Institute of Archaeology.

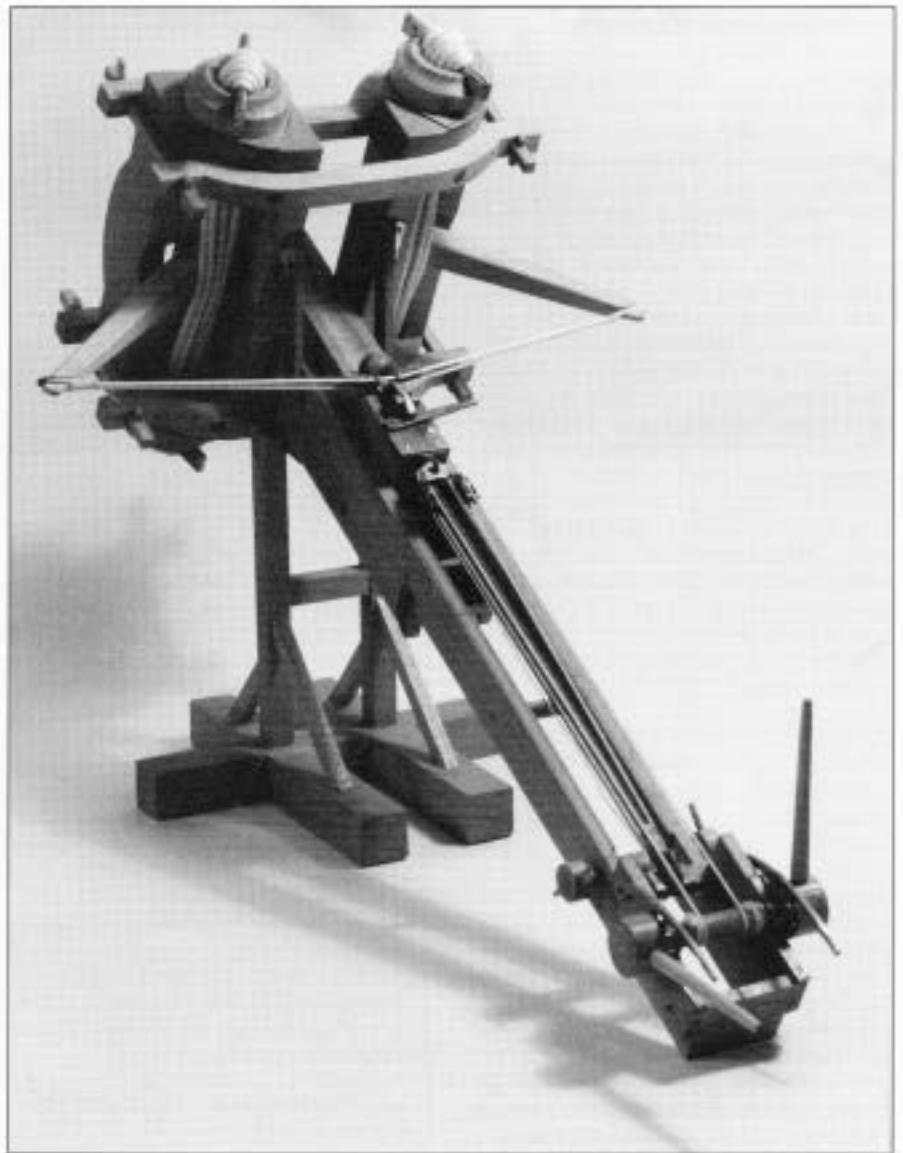
What follows is a review of three of the different approaches possible in the investigation of ancient artillery design: experimental archaeology; a study of the surviving accounts of the classical technical writers who described the machines; and the identification and examination of surviving remains revealed by archaeology. The article concludes with some observations on one aspect of the second of these themes: the illustrations that accompany the ancient texts. These provide a

potential source of additional information whose value is sometimes overlooked, and they are anyway a subject of interest in their own right.

#### **Pioneers in the study of ancient catapult design and reconstruction**

One group of men who have been fascinated by the problems involved in trying to understand ancient catapult design have,

not surprisingly, been former artillery officers. The doyen of such veterans was Major E. Schramm, who in 1918 published a classic account<sup>3</sup> of ancient artillery and the experiments that he carried out on replica machines at the reconstructed Roman fort of the Saalburg (near Frankfurt) where, 14 years earlier, he had actually demonstrated the workings of one of them in front of the Kaiser. I remember looking at a copy of Schramm’s book, *Die Antiken Geschütze der Saalburg*, in the Institute’s library when I first arrived as a student in the early 1960s. I was impressed both by the fact that the copy had belonged to R. G. Collingwood, the famous historian, philosopher and archaeologist,<sup>4</sup> and by the wonderful series of blueprints of reconstructions of ancient artillery pieces that Schramm published. One of these was based on discoveries made at excavations at Ampurias (Spain) in 1911, but for the most part they were founded on the technical descriptions, and in some cases technical drawings,



**Figure 1** Model of an artillery catapult made by Jeremy Barker, showing its general principles of operation.

given by three Greek engineers, Philon, Biton and Heron, and one Roman one, the architect and artillery engineer Vitruvius, who lived during the reign of the emperor Augustus at the end of the first century BC. Experimental archaeology has been continued, although not on the scale carried out by Schramm. Here I can do no more than mention the work of Digby Stevenson, who as a third-year undergraduate working on his dissertation at the Institute<sup>5</sup> succeeded in replicating sinew rope used (together with other organic materials) for the catapult springs – an art lost for a thousand years or more. I owe to his knowledge and skill the drawings that accompany this article.

After the Second World War, the mantle of Schramm fell on another former artilleryman, Eric Marsden of Liverpool University. Whereas Schramm was what we would today call an experimental archaeologist – and an exceptionally fine one – Marsden was a classical scholar and the fruits of his labours resulted in two monographs published in the late 1960s.<sup>6</sup> The first volume drew on a wide range of evidence, some of it archaeological, such as ancient representations and artillery fortifications, and some of it literary, such as descriptions of artillery in action in the works of contemporary writers, whereas the second volume consisted of the texts of all the relevant Greek and Roman technical treatises, meticulously edited and translated. However, although Marsden made advances on the work of Schramm, he was basically dealing with the same categories of evidence, and one vital body of information had hardly been tapped: the remains of the machines themselves. For Marsden, as for Schramm, the only surviving catapult parts known were the finds from Ampurias; and yet, ironically, parts of other machines had already been discovered, although they had not been recognized for what they were. And this – the misidentification of catapult parts – is something that is also true of many of the numerous discoveries made since the publication of Marsden's two volumes.

### The evidence of the spade: identifying the remains of catapults

Since the late 1960s when Marsden was aware of the parts of only one ancient catapult (the Ampurias finds), parts of some 36 different machines have become known. Some of these are old finds, but others have been made in the past 30 years, and they too have been subject to misidentification. The catalogue of misidentifications, old and more recent, makes amusing reading: the armour plating from the front of a catapult used at the battle of Cremona in Italy during the civil wars of AD 69 was interpreted as the front of a military pay chest by that giant of nineteenth-century scholarship, the great Theodore Mommsen. When I saw it illustrated I correctly identified it for what it was – but I then read the caption

and feebly assumed that Mommsen must be right. It was first correctly identified by Peter Connolly, an honorary research fellow at the Institute of Archaeology, and associated finds in the Museum at Cremona, ignored by Mommsen but examined by Connolly, make the identification certain. Another early find, a piece from the Athenian naval base of Sounion, was thought to be part of a balance for weighing bullion until recognized as a catapult washer by the Canadian archaeologist Hector Williams. Since Schramm's day but before Marsden wrote, discoveries from the remains of a Hellenistic fort or block house at Ephyra near Ioannina in northern Greece were claimed to come from the mechanism of an elevating platform for producing a *deus ex machina* (a sort of demon king) in a *necromanteion* or sanctuary associated with the underworld (in reality the fort). The correct interpretation of these finds awaited their republication by Schramm's successor as curator at the Saalburg-Museum, Dietwulf Baatz. Similarly, finds from a shipwreck off Mahdia on the east coast of Tunisia were thought to be a part of a pump for getting rid of bilge water; an ingenious reconstruction of the device was even published. Even after the appearance of Marsden's two books in 1967 and 1969, finds from Hatra in Iraq were interpreted at first as coming from a small cart or trolley, and others from the hot springs at Bath were identified as bits of the Roman plumbing (I can claim credit for correctly identifying the latter and well remember my excitement when I first saw the object in question).

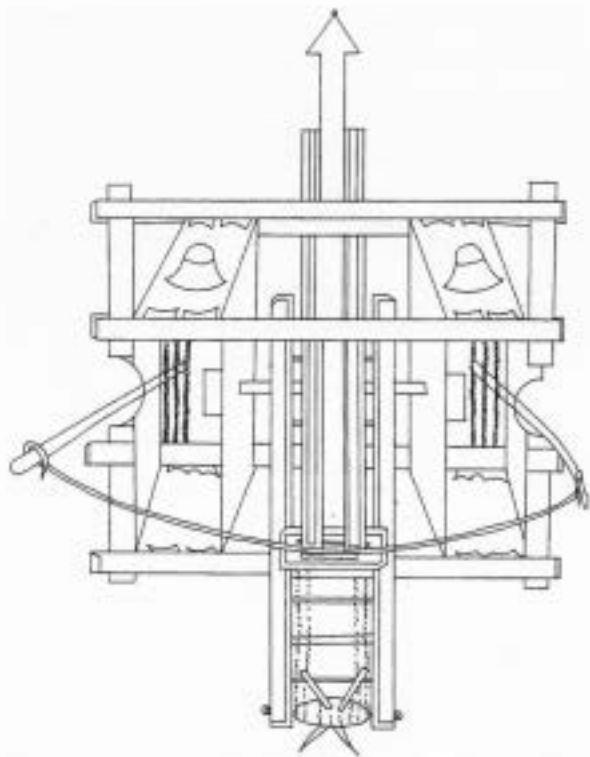
Other finds that defied interpretation were simply ignored. Michel Feugère, a young French expert on the archaeology of the Roman army, recognized a key piece while going through the reserve collection in the Museum at Lyon. Curiously, the object in question, although published by him, is still not on public display. However, by the 1970s, partly because of the appearance of Marsden's work, there was a greater awareness of what catapult parts looked like. New finds were correctly identified and usually promptly published. These include the finds of the late republican or early imperial period from Teruel in Spain, others of perhaps third-century date from Pityus on the southeastern shore of the Black Sea and Sala in Morocco, and the important late Roman discoveries from the Romanian sites of Gornea and Orsova. Much of this new material has been published in articles by Dietwulf Baatz<sup>7</sup> and, along with reprints of the Marsden and Schramm books, they are an essential source of information for anyone seriously interested in the subject.

### Neglected evidence: the ancient technical drawings

Although the number of recognizable catapult parts has grown enormously since Marsden's day, there are still very real

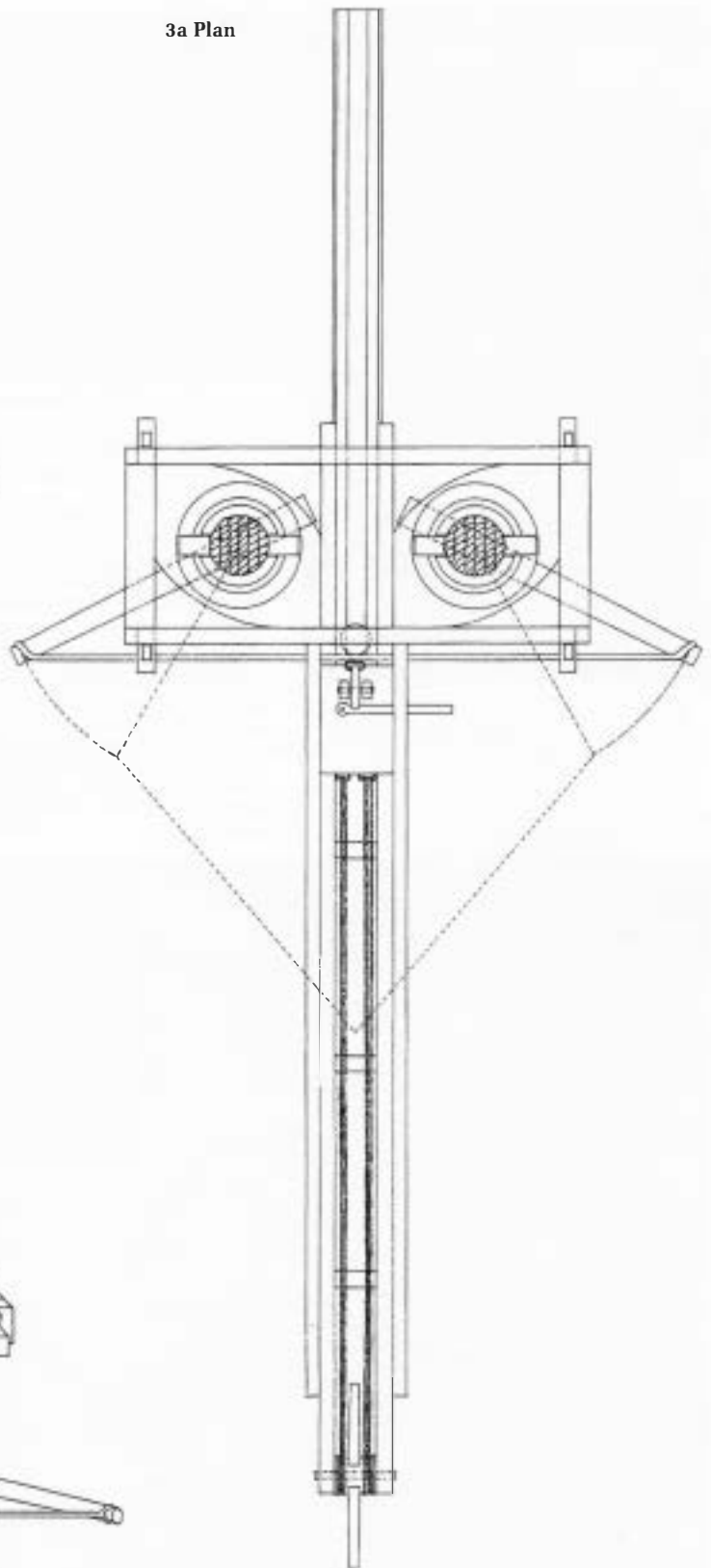
problems in interpreting how some of the machines attested both by the technical writers and in the archaeological record actually worked. This is especially true of the type of machine introduced about AD 100, during the reign of the emperor Trajan, when there appears to have been something of a revolution in catapult design. The arguments are technical and beyond the scope of this article, but if the problems can be solved, it will only be by examining the different categories of evidence alluded to above: the growing body of archaeological evidence, the results of archaeological experiments, and the descriptions left by technical writers and the drawings that accompany them. This last category of evidence has in the past been largely neglected, even by Marsden, who published the texts of the technical writers in such exemplary fashion. The truth is that technical illustration in the classical (Greek and Roman) period was, to say the least, undeveloped. The conventions used are not those that would be employed by a technical draughtsman today. This would not matter if they had at least been consistent, but they were not. It was as if the drawings were intended only as guidelines for people who were already familiar with what was being represented. Those who studied the ancient artillery from the Renaissance to the end of the nineteenth century no longer possessed that familiarity. However, because of the increase in the archaeological evidence, this is no longer quite so true and the time is ripe to look again at the technical drawings.

The problems posed by the classical technical drawings can be illustrated by Figures 2 and 3. Figure 2 shows the sort of illustration that accompanied Heron's description of one type of catapult – a so-called palintone ballista. Modern technical draughtsmen normally employ a single convention in the same drawing, as in the case of the blueprints of catapults published by Schramm, which are either elevations or plans. Heron's illustration (Fig. 2), surprisingly, combines two conventions in the same drawing: a plan view and a perspective. In Figure 3 an attempt is made to "unscramble" this combination drawing, with a plan of the machine as a whole (Fig. 3a), an elevation of a detail (Fig. 3b) and a perspective (Fig. 3c). Perspective drawing is a convention that a technical draughtsman of today would not normally use unless preparing something for a non-technically minded client. Instead he would use isometric drawings<sup>8</sup> and elevations, as well as plans. The result is superficially like a perspective but has the great advantage of allowing measurements to be taken directly from it, as there is no reduction in scale relating to distance. Draughtsmen in the ancient world did not use this particular convention. Indeed Greek and Roman artists were unaware of the true laws of perspective, even if they sometimes attempted to use perspective in wall paintings, for

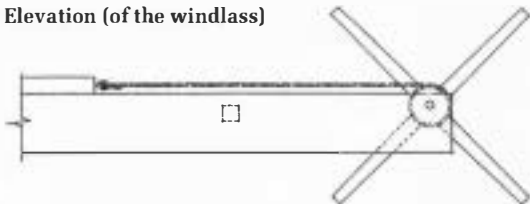


**Figure 2** Redrawing (by Digby Stevenson) of the palintone ballista, as described by Heron in the *Belopoeica*, based on figure 31 in *La polycétique des Grecs*, C. Wescher (Paris: l'Imprimerie Impériale, 1867). Wescher's illustration is a composite derived from two of the original manuscript versions, Codex P76 v. and Codex V.115 v. The former version is conveniently reproduced by Schramm (see n. 3).

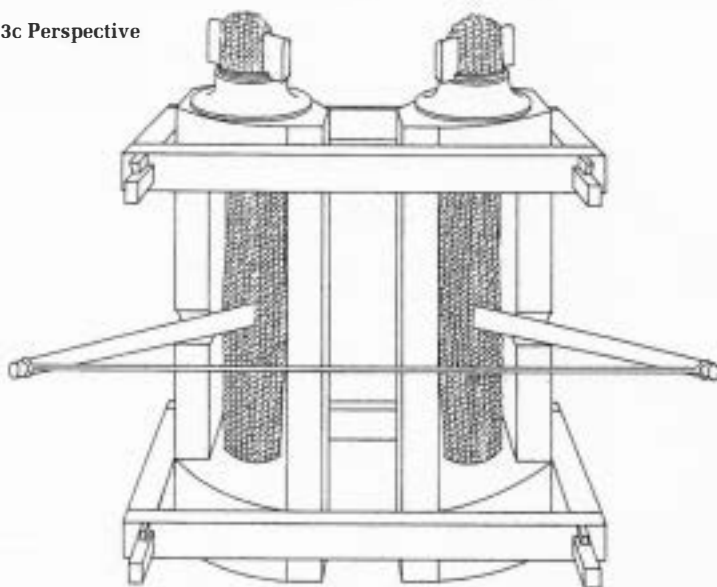
3a Plan



3b Elevation (of the windlass)



3c Perspective



**Figure 3** Interpretations the type of machine illustrated by Heron using modern conventions (all by Digby Stevenson)

some scenes employ an impossible three or more vanishing points in the same composition.

This is to touch only briefly on a large and interesting subject. Apart from the two different conventions used by Heron (perspective and plan), others can be used. Besides plan, elevations and isometric (and axonometric)<sup>9</sup> drawings, the modern technical draughtsman can use cutaway and sectional drawings. Most of these conventions were unknown in the ancient world, although at least one artist used the cutaway technique in his representation of an Assyrian siege machine.<sup>10</sup> In the past, other conventions (to us more alien) were sometimes used in the depictions of ancient artillery. If we are to understand them and the machines they attempted to portray, we must try to get into the minds of the draughtsmen working in a bygone age, with no established conventions and only their own ingenuity to rely on.

## Notes

1. The motive force for ancient artillery was provided by two springs held in a vertical position within a heavy frame, which, in earlier machines, was made of wood (Fig. 1). Each spring consisted of a single length of rope made of sinew or hair, which was threaded through holes in the upper and lower elements of the frame. After emerging from the holes it passed over short bars of metal held in place at top and bottom by bronze so-called spring washers. These spring washers consisted of a vertical ring of metal with a horizontal flange near the bottom of the ring and were cast in one piece with it. The part of the ring below the flange fitted snugly into the hole in the wooden frame, and the part above had recesses into which the bar fitted. Holes were drilled around the circumference of the flange. Once the springs had been wound into position through the frame and over the bars in the washers, the washers could be rotated so as to twist the skein of rope. When the degree of torsion required had been achieved, the washers were locked into position by pins that passed through the holes in the flange into corresponding holes in the frame.
2. The Auerberg moulds were used for casting bronze catapult washers by the lost-wax process. Wax models of the casting were first made and then encased in clay. The molten metal was then introduced through a hole in the clay mantle. This caused the wax to evaporate and the void it had once occupied to be filled with the metal. That the original wax models for the washers were turned on a lathe, used in conjunction with a metal template, is shown not only by the regularity of their circular form, but also by fine striations on the inside of the mould fragments.
3. E. Schramm, *Die antiken Geschütze der Saalburg* (Berlin: Weidmannsche Buchhandlung, 1918). Republished with a new introduction by D. Baatz as *Beiheft of the Saalburg-Jahrbuch* (Bad Homburg: Saalburg-Museum, 1980).
4. On checking to see that my memory served me correctly about Collingwood's signature, I found that the volume had been rebound and that the evidence had, sadly, been lost.
5. D. Stevenson, *Heron's Cheiroballistra, with an appendix on the manufacture of sinew rope* (BA dissertation, University College London, 1995).
6. E. W. Marsden, *Ancient artillery*, vol. I: *historical development and ancient artillery*, vol. II: *technical treatises* (Oxford: Oxford University Press, 1967, 1969). Republished (London: Sandpiper, 1998).
7. D. Baatz, *Bauten und Katapulte des römischen Heeres*. Published in English as vol. XI in the series, *Mavors Roman Army Researches*, M. P. Speidel (series ed.) (Stuttgart: Franz Steiner, 1994).
8. Isometric drawings are defined by the *Concise Oxford dictionary* as ones "with the plane of projection at equal angles to the three principal axes of the object shown".
9. The *Concise Oxford dictionary* defines axonometric as "(of a pictorial representation) using an orthographic projection of the object on a plane inclined to each of the three principal axes of the object".
10. From one of the scenes on the bronze gates of Shalmaneser III (858–824 BC) at Balawat, now in the British Museum, reproduced on p. 401 in *The art of warfare in Biblical lands in the light of archaeological discovery*, Y. Yadin (London, Weidenfeld & Nicholson 1973).